



VISIT THE LIFETIME WEB SITE:

**WWW.LIFETIME.COM**

**\*\*U.S. and Canada customers ONLY\*\***  
**IF ASSISTANCE IS NEEDED,**

**DO NOT CONTACT THE STORE!!!**

**CALL OUR CUSTOMER SERVICE DEPARTMENT at 1 (800) 225-3865**

**HOURS: 7:00 a.m. to 5:00 p.m. Monday through Friday (Mountain Standard Time)**

**\*\*For customers outside the U.S. or Canada, please contact the store for assistance.\*\***

## **CHAIR STORAGE CART**

**ASSEMBLY INSTRUCTIONS AND OWNER'S MANUAL**

**MODEL #6525**

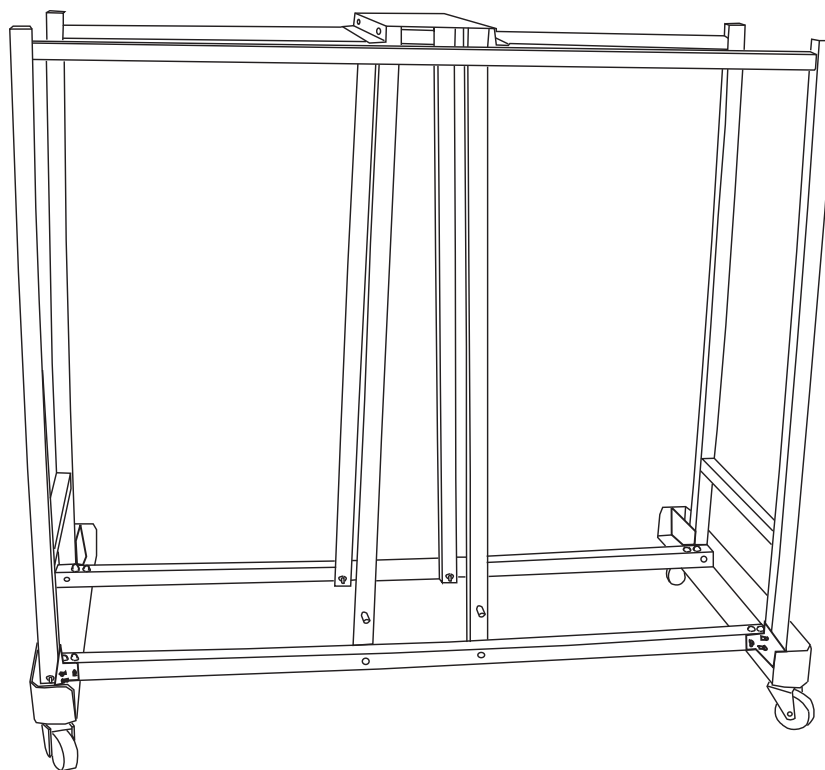

### **WARNING**



Failure to comply with any of the warnings in these instructions may result in serious personal injuries such as cuts, broken bones, nerve damage, paralysis, brain injury, or death. Failure to comply may also result in property damage. Please heed all warnings and cautions. To ensure your safety, do not attempt to assemble this cart without reading and following **all** instructions carefully. Identify and inventory the parts using the Parts List.

**Save this instruction in the event that the manufacturer has to be contacted for replacement parts.**

# PARTS LIST

ID	Description	Qty	✓
CJG	Angled Caster Frame	2	<input type="checkbox"/>
CJH	Bottom Tube	2	<input type="checkbox"/>
CJI	Angle Support	2	<input type="checkbox"/>
CJJ	Top Rail	2	<input type="checkbox"/>
CJK	Center Brace	4	<input type="checkbox"/>
CJL	Right Corner Upright	2	<input type="checkbox"/>
CJM	Left Corner Upright	2	<input type="checkbox"/>
CJN	Top Panel	1	<input type="checkbox"/>
CIR	Caster	4	<input type="checkbox"/>
CIS	Plastic Cap	4	<input type="checkbox"/>
<b>CJQ</b>	<b>Table Cart Hardware</b>		
CJO	m8 x 57 mm Bolt	8	<input type="checkbox"/>
CJP	m8 x 87 mm Bolt	8	<input type="checkbox"/>
CIX	m8 Flat Washer	64	<input type="checkbox"/>
CIY	m8 Nylock Nut	32	<input type="checkbox"/>
CIZ	m4 x 10 mm Self-Tapping Screw	8	<input type="checkbox"/>
CJA	5 mm Allen Wrench	1	<input type="checkbox"/>
CJB	13 mm Wrench	1	<input type="checkbox"/>
CJC	m8 x 53 mm Bolt	16	<input type="checkbox"/>

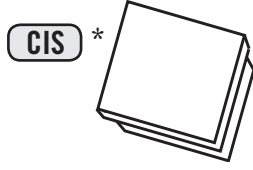
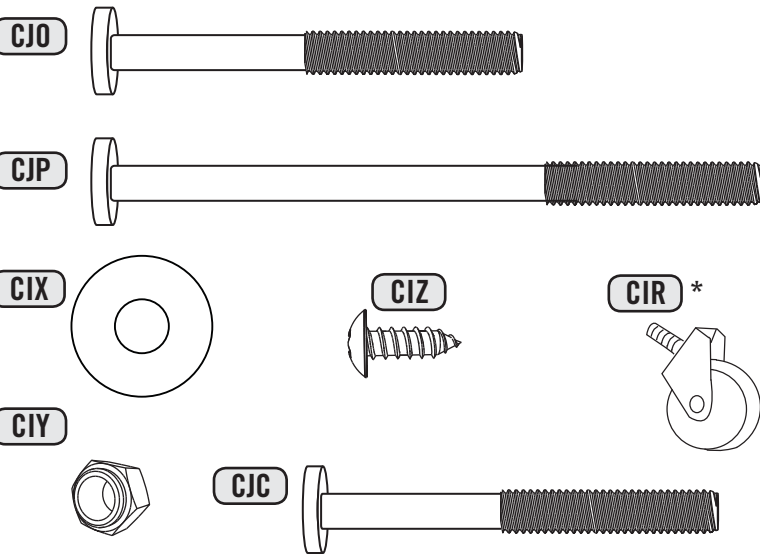
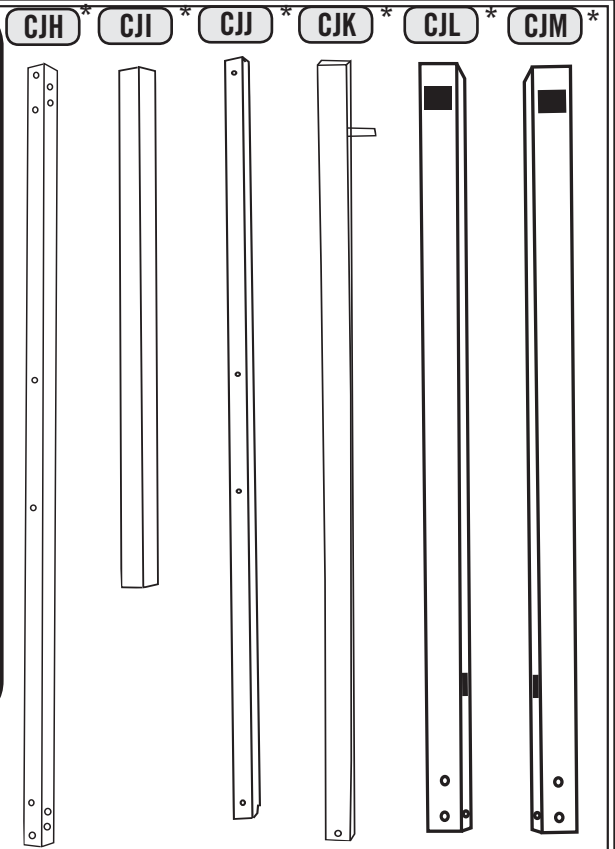

\*Not actual size

**Tools and Materials Required for Assembly (Not Included)**

1. Phillips Screwdriver

**\*\* A MINIMUM OF TWO ADULTS ARE REQUIRED FOR ASSEMBLY \*\***

## STOP! BEFORE BEGINNING ASSEMBLY STOP!

A. Identify and inventory all parts using the checklist boxes on the Parts List. If any parts are missing, call our Customer Service Department.

## SAFETY INSTRUCTIONS

**FAILURE TO FOLLOW THESE SAFETY INSTRUCTIONS MAY RESULT IN SERIOUS INJURY OR PROPERTY DAMAGE AND WILL VOID THE WARRANTY. Proper and complete assembly, use and supervision is essential for proper operation and to reduce the risk of accident or injury.**

- If technical assistance is required, contact the manufacturer.
- No one should play on or around the chair carts. The cart should never be left on a slope, as it could roll and cause serious personal injury or property damage. A loaded cart is heavy and should be handled by someone capable of handling the weight.

*Most injuries are caused by misuse and/or failure to follow instructions.*

## STEP 1

- a. Secure the two **Bottom Tubes (CJH)** to the **Caster Frames (CJG)** by inserting **m8 x 53 mm Bolts (CJC)** through **m8 Flat Washers (CIX)**, down through each of the holes in the Caster Frames and Tubes and through **m8 Flat Washers (CIX)**. Secure only finger tight with **m8 Nylock Nuts (CIY)**.

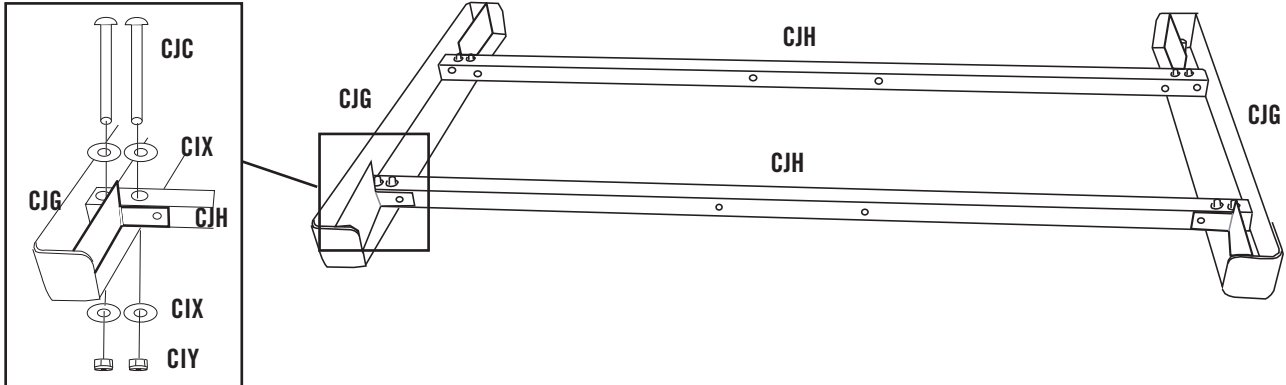

## STEP 2

- a. Place a **Right Corner Upright (CJL)** next to the **Bottom Tube (CJH)** in the **Caster Frame (CJG)** as shown. The square hole near the bottom of the Upright should face the Bottom Tube. The square hole at the top of the Upright should face the opposite end of the cart.
- b. Slide an **m8 Flat Washer (CIX)** over an **m8 x 87 mm Bolt (CJP)** through the holes in the Bottom Tube and the Upright. Slide an **m8 Flat Washer (CIX)** over the Screw and secure finger tight with an **m8 Nylock Nut (CIY)**.

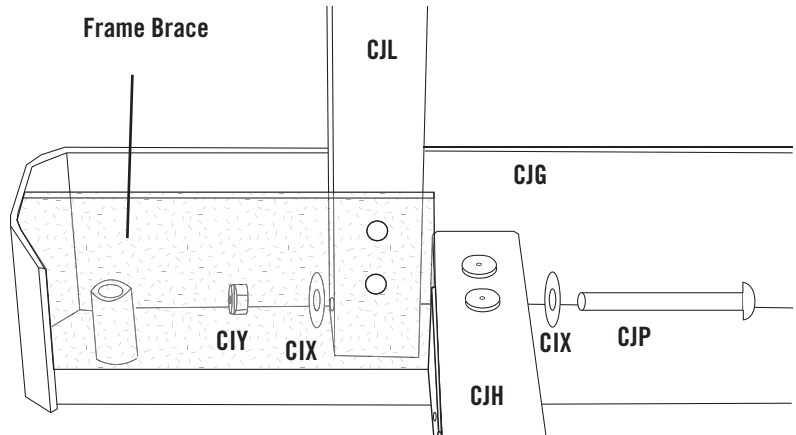

## STEP 3

- a. Secure the **Right Corner Upright (CJL)** to the **Caster Frame (CJG)** with two **m8 x 57 mm Bolts (CJO)**, four **m8 Flat Washers (CIX)** and two **m8 Nylock Nuts (CIY)**. *Only finger tighten the Nuts now.*

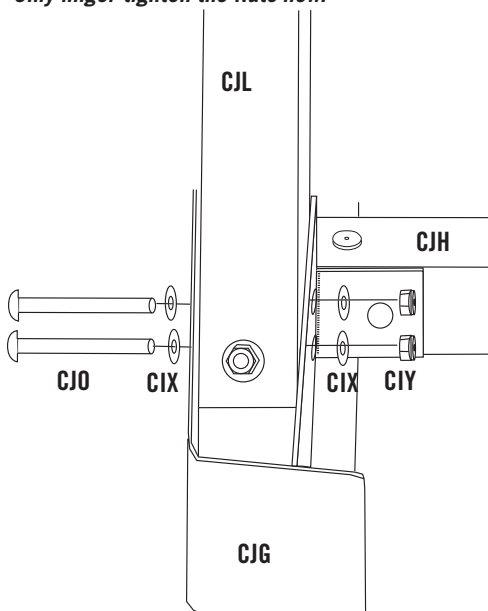

## STEP 4

- a. Secure the **Bottom Tube (CJH)** to the brace frame on the **Caster Frame (CJG)** with a **m8 x 53 mm Bolt (CJC)**, **m8 Flat Washers (CIX)** and **m8 Nylock Nuts (CIY)** as shown. *Only finger tighten the Nut now.*

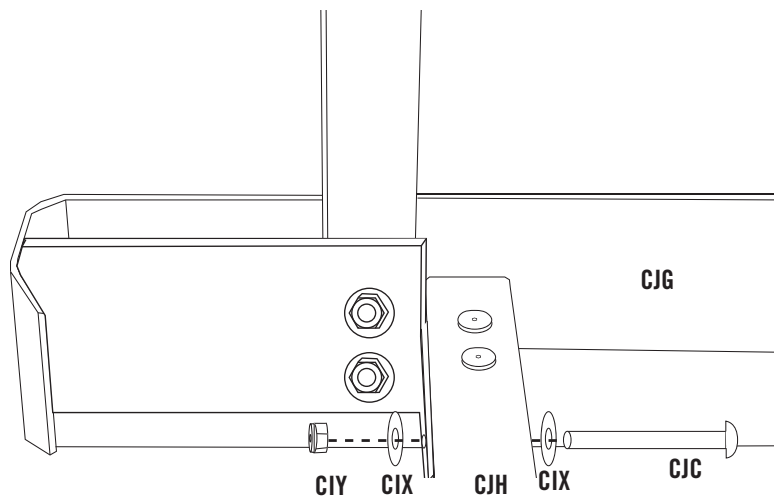

## STEP 5

- Insert an **Angle Support (CJI)** into the square hole near the bottom of the **Right Corner Upright (CJL)**. Slide a **Left Corner Upright (CJM)** into the Support and secure the bottom of the Upright to the Bottom Tube and Caster Frame as shown in Steps 2 through 4.
- Repeat Steps 2 through 5 to attach the other set of Uprights to the other end of the Cart.

**Note:** The Left and Right Corner Uprights will be installed on opposite corners from each other. See the illustration in Step 6.

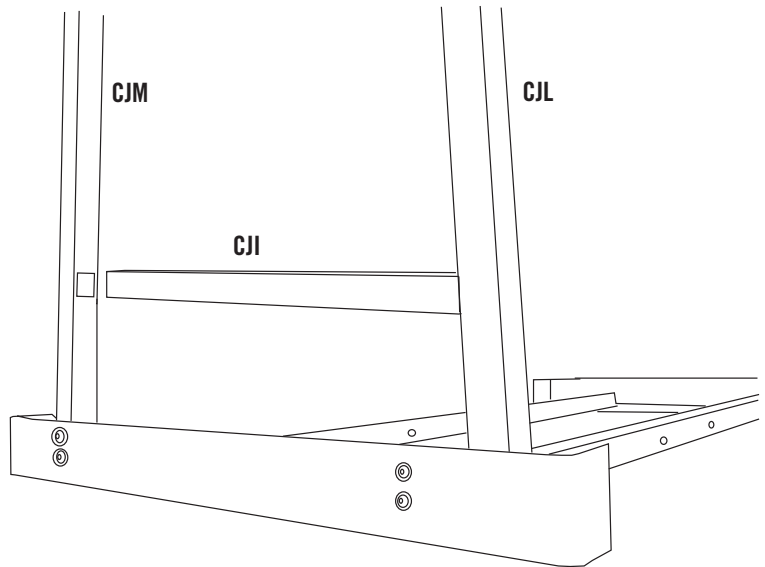

## STEP 6

- Insert the **Top Rails (CJJ)** firmly into the square holes in the **Corner Uprights (CJL & CJM)**. The small holes in the Rails should face up. Make sure the Top Rails are pulled in tightly to the Corner Uprights.
- Insert a **m4 x 10 Phillips Head Screw (CIZ)** into the holes in the Top Rails inside each Upright as shown.

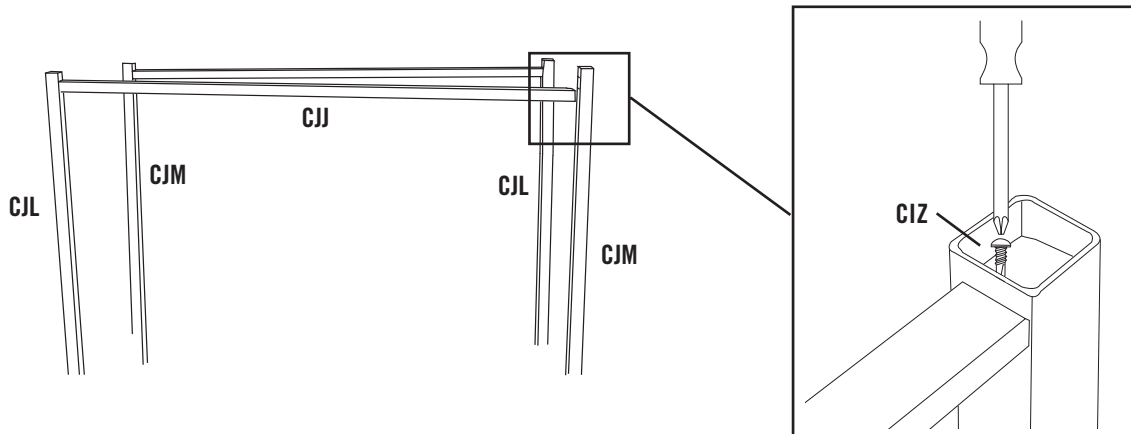

## STEP 7

- Attach each **Center Brace (CJK)** to the **Top Panel (CJN)** with an **m8 x 53 mm Bolt (CJC)**, **m8 Flat Washers (CIX)** and an **m8 Nylock Nut (CIY)** as shown. The Bolt head should be on the outside of the assembly. Make sure the locking pins at the ends of the Braces face out as shown. **Only finger tighten the Nut now.**  
**Note:** It may be easier to attach the Center Braces (CJK) to the Top Panel (CJN) after the Top Panel is attached to the cart (see steps 7 and 8).

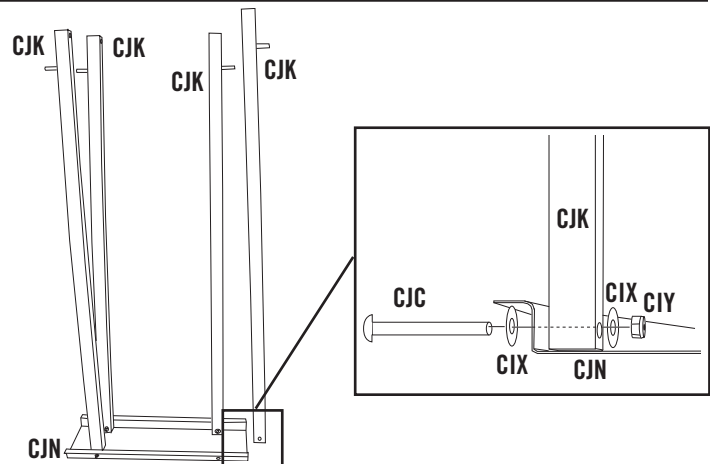

## STEP 8

- Place the Center Brace/Top Panel assembly onto the Chair Cart as shown. Make sure the Center Braces go on the inside of the Bottom Tubes.
- Insert the **Plastic Caps (CIS)** into each of the four Uprights.

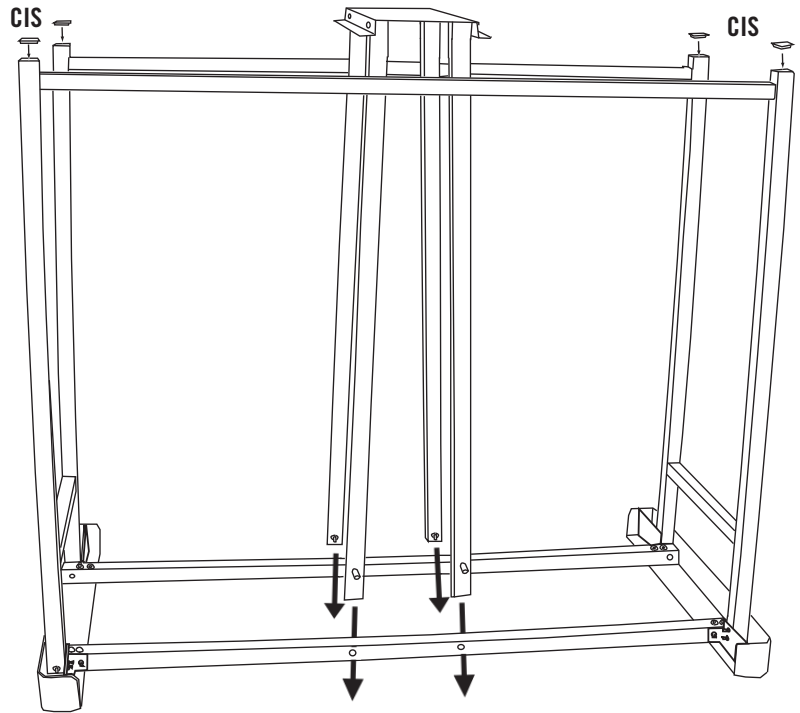

## STEP 9

- Insert a **m4 x 10 Phillips Head Screw (CIZ)** through the four holes in the **Top Panel (CJN)** and into the **Top Rails (CJJ)**.

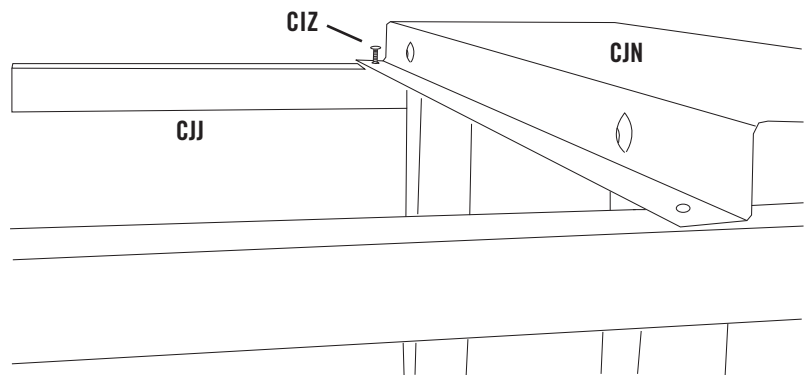

## STEP 10

- Secure the **Center Braces (CJK)** to the **Bottom Tubes (CJH)** with an **m8 x 87 mm Bolt (CJP)**, **m8 Flat Washers (CIX)** and an **m8 Nylock Nut (CIY)** as shown.
- Make sure the Cart is sitting flat and square, then completely tighten all hardware. You may need to turn the cart on its side to tighten all the hardware.

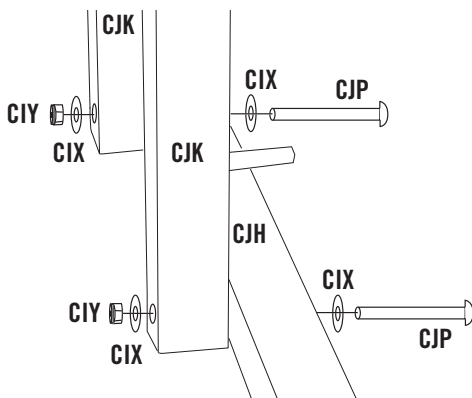

## STEP 11

- Insert the **Casters (CIR)** into the bottom of the Cart.

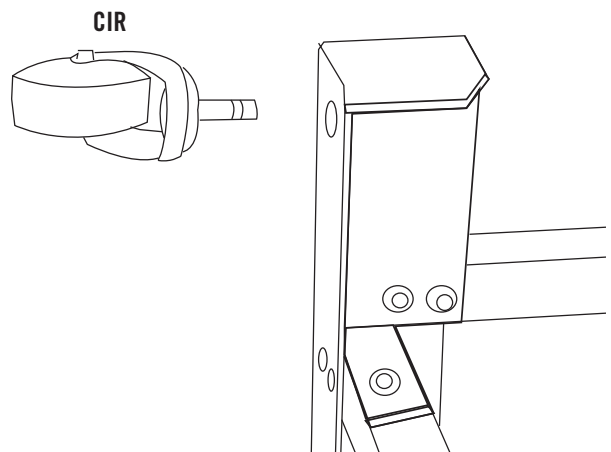



## WARNING



Chairs must be loaded leg-first into the cart. The legs of the bottom chair must rest on the bottom tube, under the locking pin. This will help prevent the stacked chairs from falling out.



## WARNING



This cart is made to carry chairs. Riding on the cart or playing near the cart while in use may cause injury. The cart is designed to be used on a level floor and should not be left on ramps, docks, or places where it might roll off or tip over. We recommend that the cart be steered and maneuvered by two competent adults who can handle and control the loaded mass of the chairs.



### WARNING

- Do not climb, ride or play on the cart.
  - The cart should only be moved by adults who can handle the weight of the loaded cart.
  - Use only on level ground.
  - The legs of the bottom chair must be underneath the locking pins.
  - Do not stack the chairs above the top bar.
- Failure to follow these warnings may result in serious personal injury. This cart is designed specifically for Lifetime® chairs.

Part #FS02300

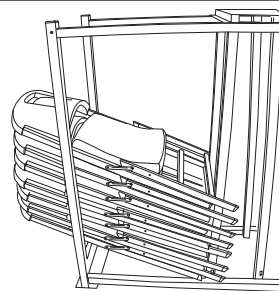

**The chairs must be loaded with the seat surface facing up.**