

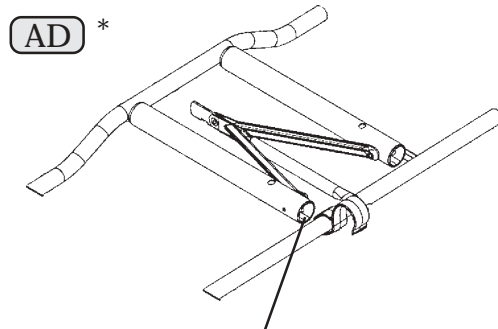

## 2125 PARTS LIST

ID	Part #	Description	Qty	✓
AA	ZP04800	Table Top Assembly	1	<input type="checkbox"/>
AB	ZP01600	Bench Assembly	2	<input type="checkbox"/>
AC	ZP71706	Table Leg Assembly	2	<input type="checkbox"/>
AD	ZP97006	Brace Assembly	2	<input type="checkbox"/>
AE	CH02200	Leg Latch	2	<input type="checkbox"/>
AF	C030002	Bushing (Attached)	4	<input type="checkbox"/>

**TWO ADULTS ARE NECESSARY TO COMPLETE ASSEMBLY!!**

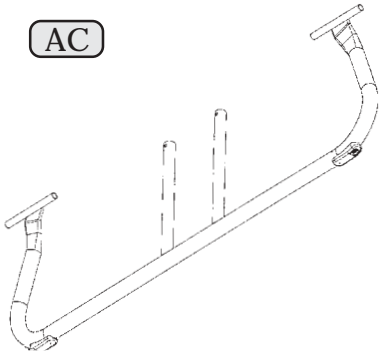
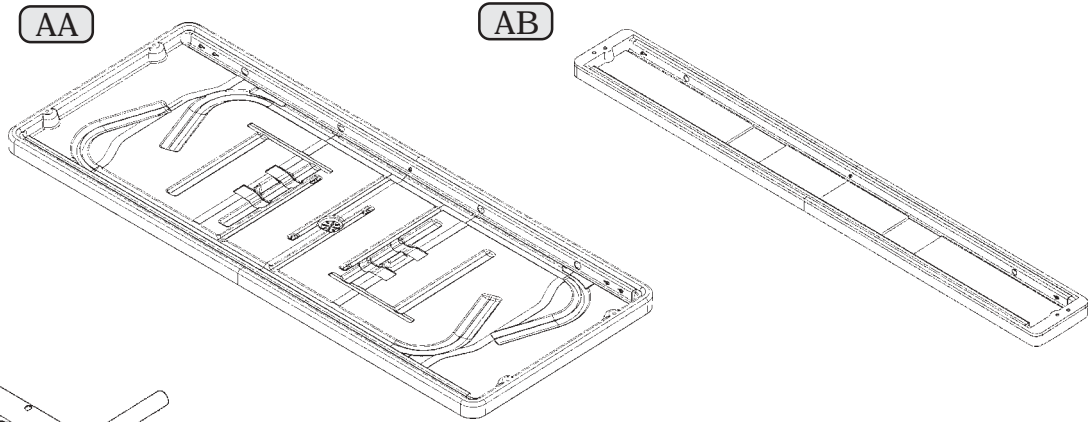

\*Make sure the Bushings (AF) are inserted into the Brace Assemblies.

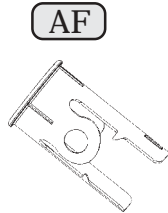
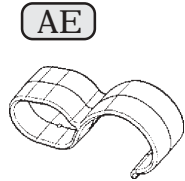

### Tools and Materials Required for Assembly (Not Included)

1. Adjustable Wrench
2. 3/8" Wrench
3. Screwdriver/Electric Drill

### NOTE:

If two or more people are sitting at the table at the same time, we recommend they sit across the table from each other to prevent possible tipping of the table.



## BEFORE BEGINNING ASSEMBLY



A. Identify and inventory all parts using the checklist boxes on the parts list. If any parts are missing, call our Customer Service Department.



## SAFETY INSTRUCTIONS



FAILURE TO FOLLOW THESE SAFETY INSTRUCTIONS MAY RESULT IN SERIOUS INJURY OR PROPERTY DAMAGE AND WILL VOID THE WARRANTY. Proper and complete assembly and use is essential for proper operation and to reduce the risk of injury. 2 people are required for assembly. • If technical assistance is required, contact the manufacturer.

*Most injuries are caused by misuse and/or failure to follow instructions.*

1A

For easier assembly, remove the Table Leg Assembly (AC) from the Brace Assemblies (AD).

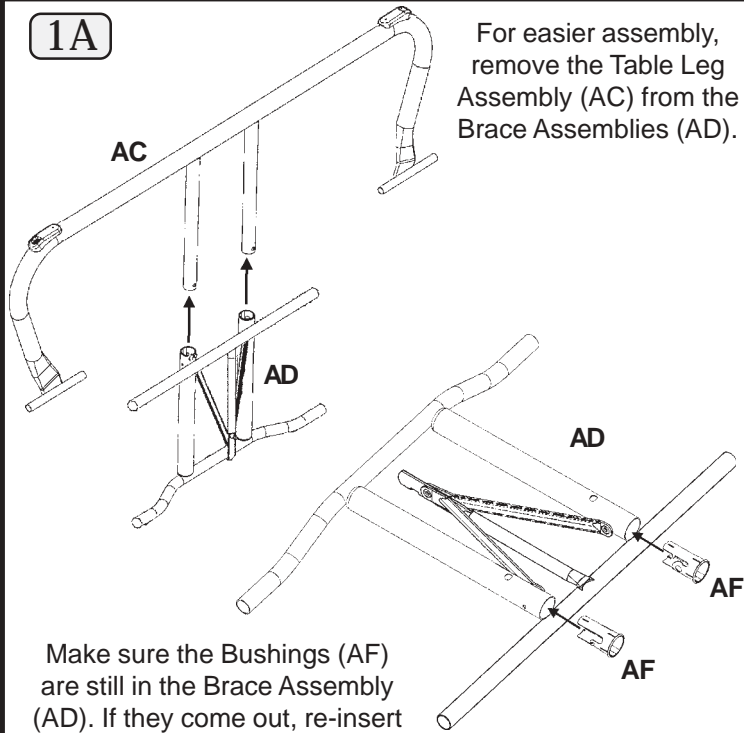

Make sure the Bushings (AF) are still in the Brace Assembly (AD). If they come out, re-insert them as shown.

1B

Place the Table Top (AA) upside-down on the floor or a table.

Remove one of the J-Channels from the Table Top by removing the Screws that hold the J-Channel in place. Save the Screws for use later in the assembly.

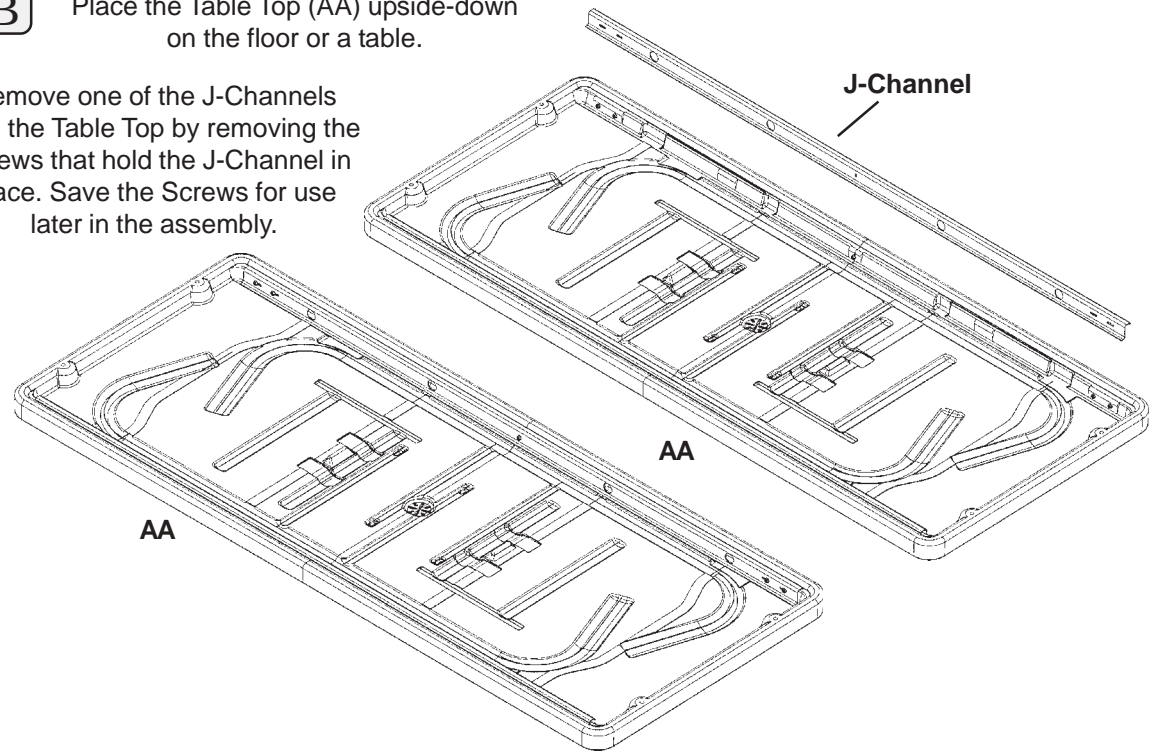

2A

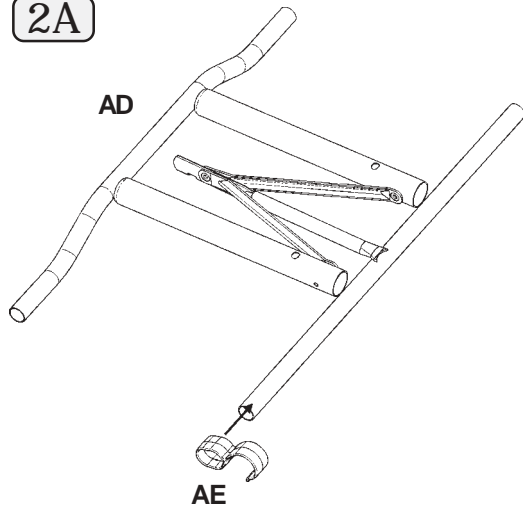

Make sure the Leg Clips (AE) are on the Brace Assemblies (AD) as shown.

2B

**\*\*Two Adults Required for This Step\*\***

The Leg Latches should be facing down as shown.

Do not put the J-Channel on upside down. Refer to the installed J-Channel for the correct orientation.

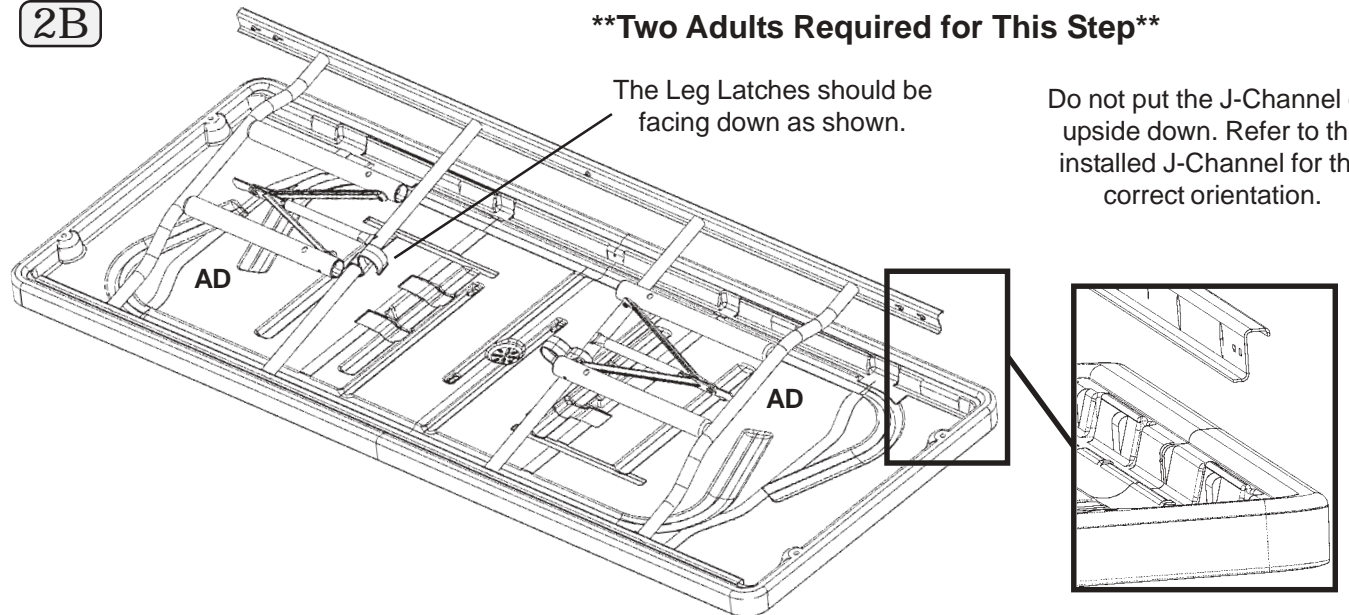

3

**\*\*Two Adults Required for This Step\*\***

Place the J-Channel back into the Table Top. Make sure the J-Channel fits into the groove in the Table.

Insert the Screws back into each hole in the J-Channel. Attach the Screw in the middle of the J-Channel first. Use the same holes in the Table that the Screws were removed from.

Tighten the Screws only until the head of the Screw makes contact with the J-Channel.

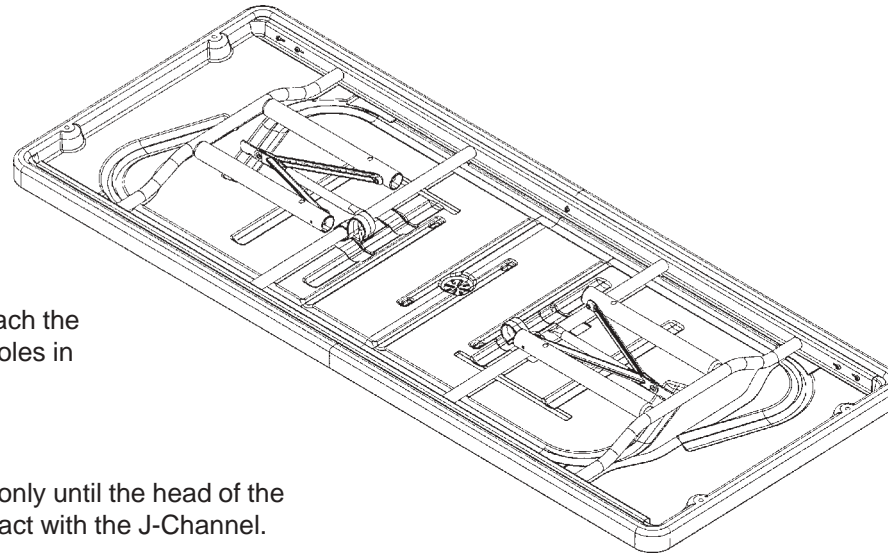

4

Rotate the Brace Assemblies (AD) up as shown.

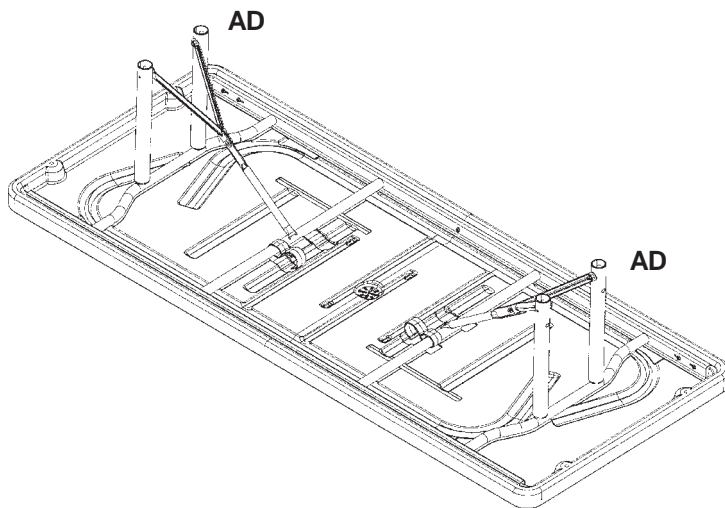

5

Insert the Table Leg Assemblies (AC) into the Brace Assemblies (AD).

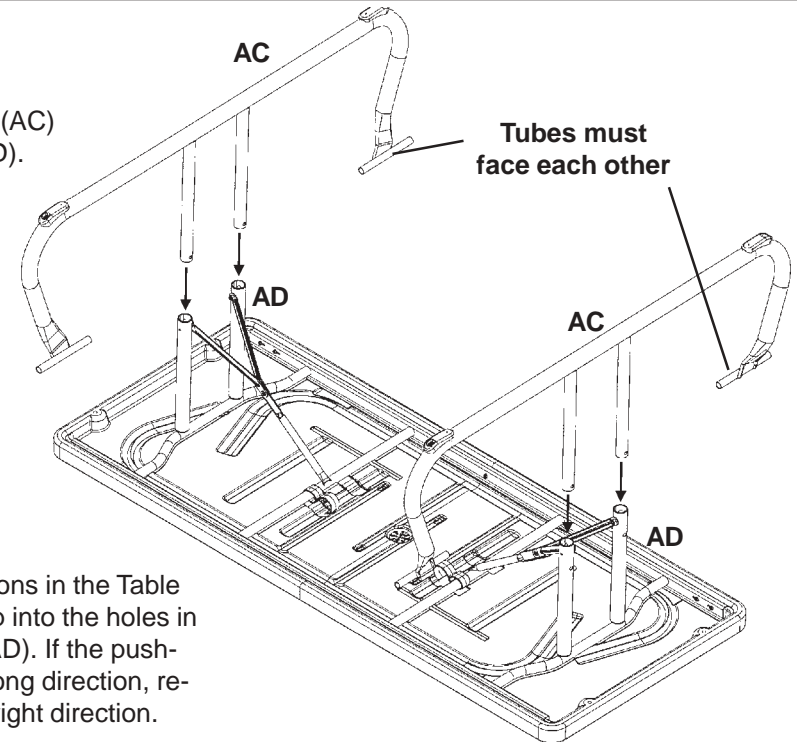

Make sure the push-buttons in the Table Leg Assemblies (AC) snap into the holes in the Brace Assemblies (AD). If the push-buttons are facing the wrong direction, re-insert them facing the right direction.

6

Remove one J-Channel from a Bench (AB) by removing the Screws that hold the J-Channel in place. Save the Screws for use later in the assembly.

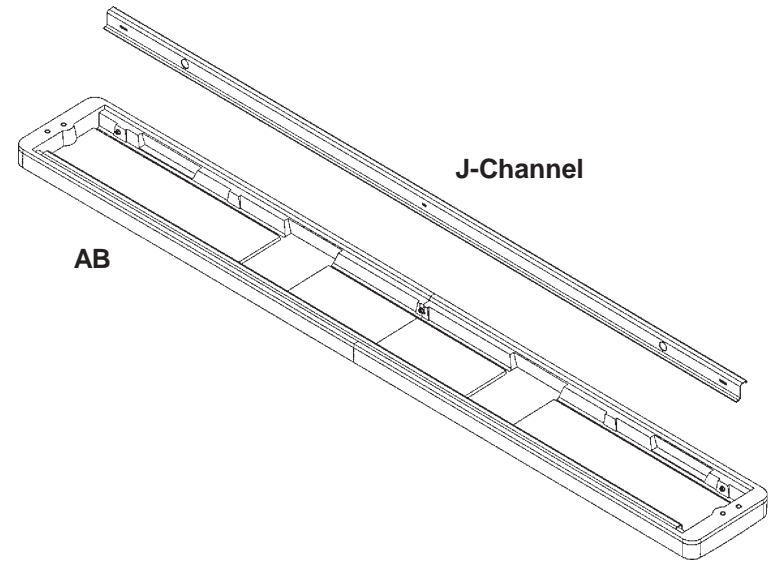
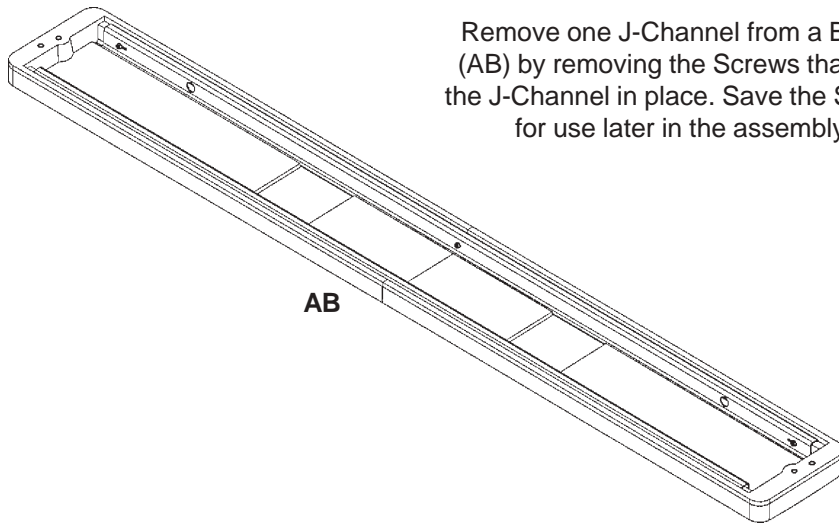

7

**\*\*Two Adults Required for This Step\*\***

Place the J-Channel onto the tubes of the Table Leg Assembly (AC) as shown. Tilt the Bench and insert the other J-Channel (attached to the Bench) onto the Table Leg Assembly.

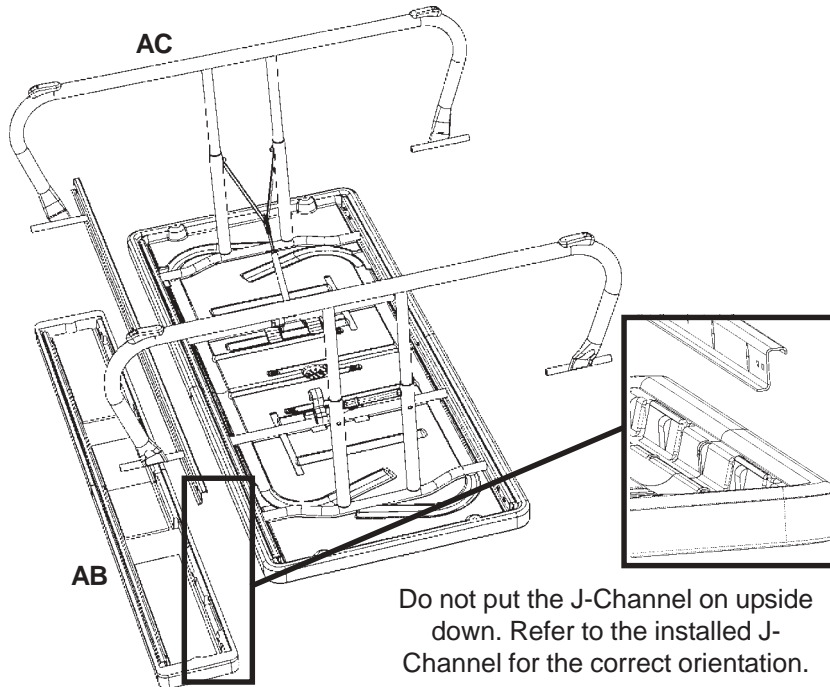

Do not put the J-Channel on upside down. Refer to the installed J-Channel for the correct orientation.

8

**\*\*Two Adults Required for This Step\*\***

Place the J-Channel back into the Bench. Make sure the J-Channel fits into the groove in the Bench.

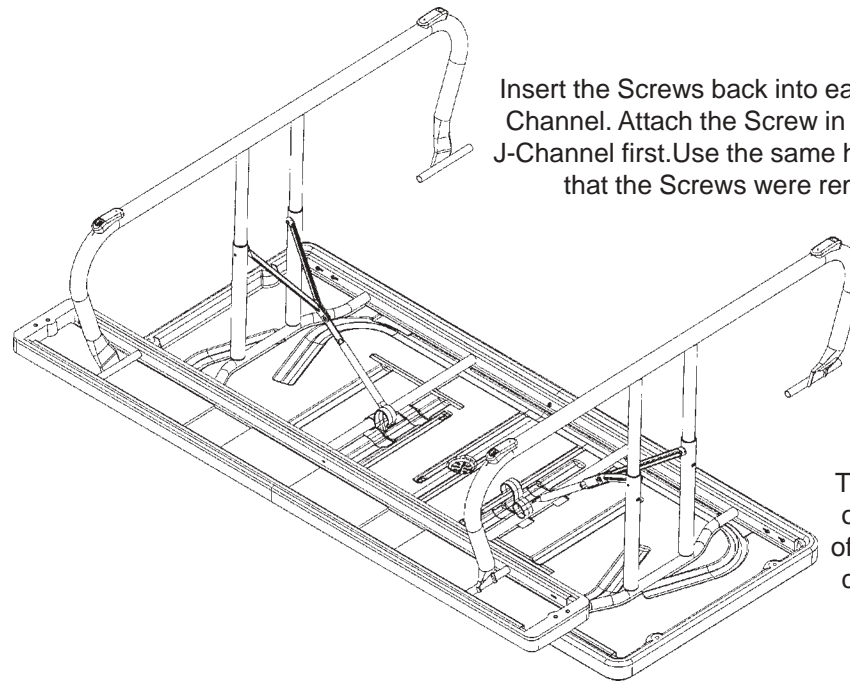

Insert the Screws back into each holes in the J-Channel. Attach the Screw in the middle of the J-Channel first. Use the same holes in the Bench that the Screws were removed from.

Tighten the Screws only until the head of the Screw makes contact with the J-Channel.

9

Repeat Steps 6 through 8 to attach the other Bench.

10

**\*\*Two Adults Required for This Step\*\***

Using two adults, set the table upright.

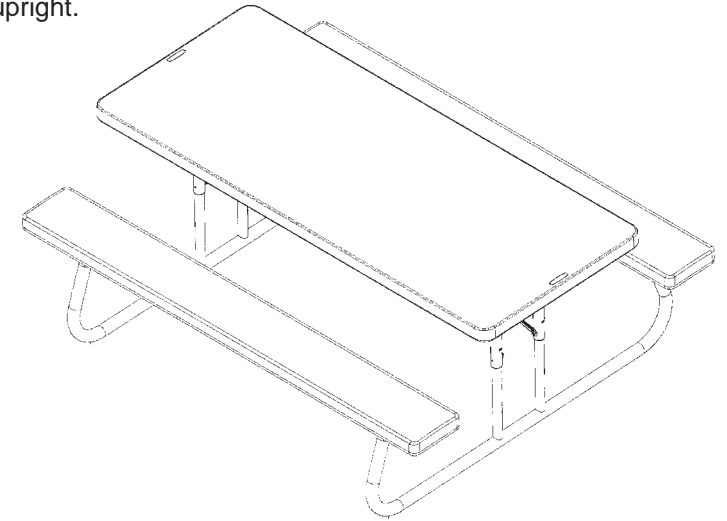
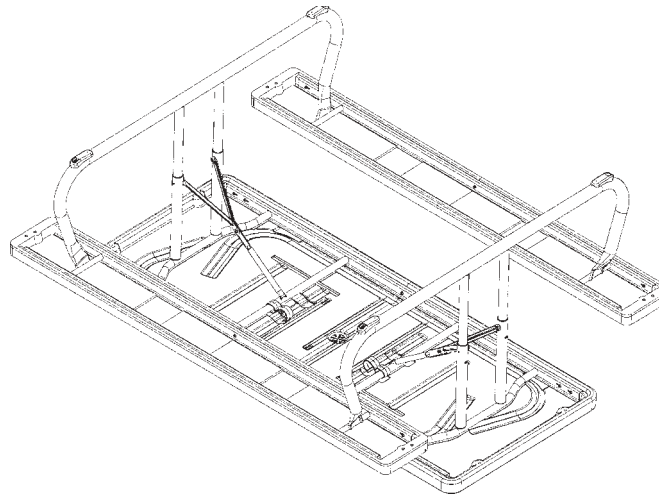

To prevent the Leg Latches (AE) from dangling when the table is set up (Figure 1), slide the Latches toward the ends of the table (Figure 2) so they're in the position shown in Figure 3.

Figure 1

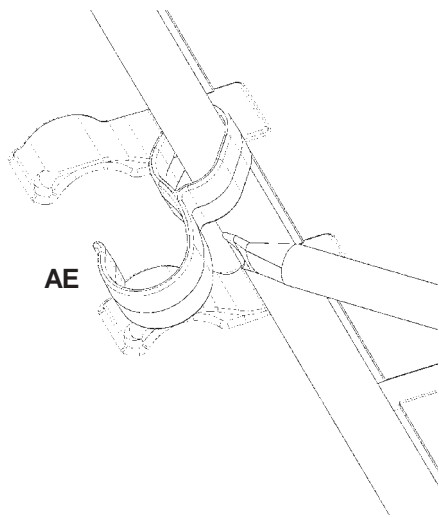

Figure 2

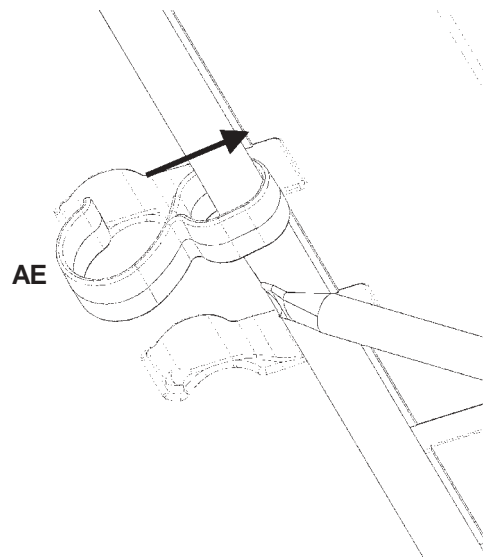
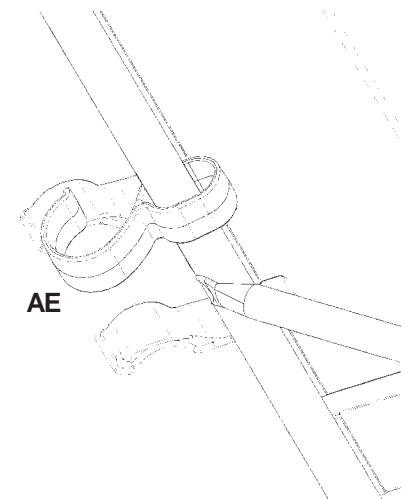
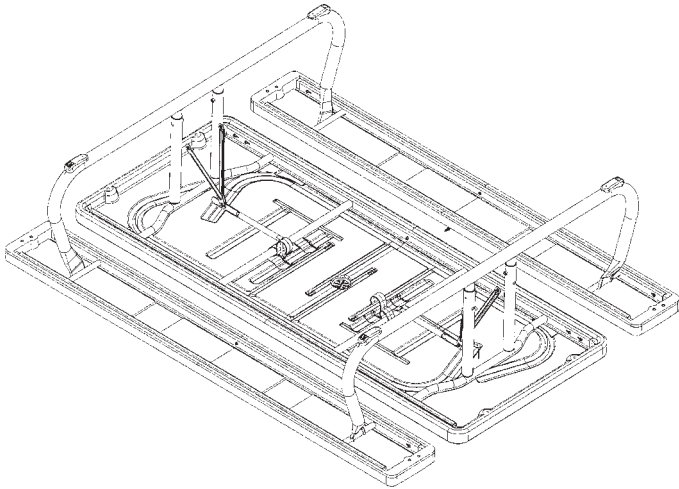

Figure 3



## Storing the Table

Make sure the Legs are in the lowest position and fold the Legs down.



Secure the Legs with the Leg Latches as shown. Unhook the Latches before setting the table up.

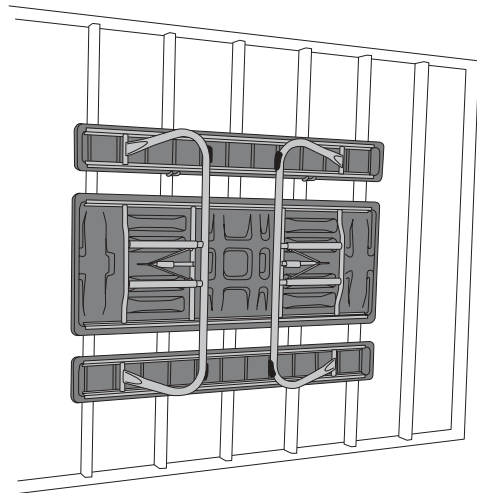
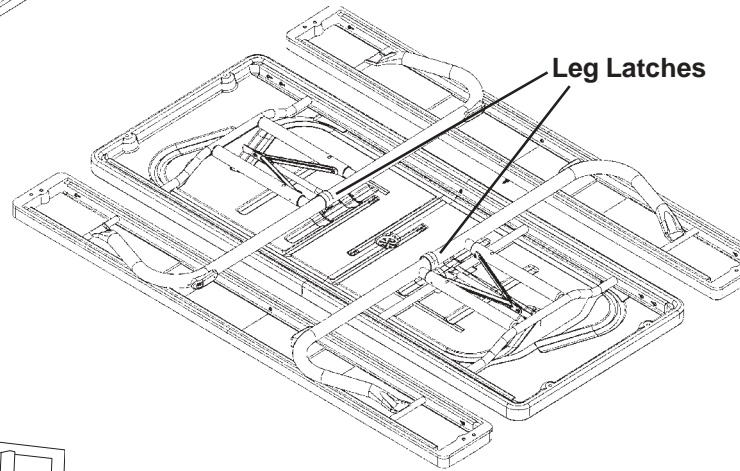

Care should be taken when hanging the table on a wall for storage. Two hooks capable of holding at least 100 pounds each are required. Securely fasten the hooks into solid framework to prevent them from coming loose and the table from falling. For safety purposes, two people are required to hang and take down the picnic table to avoid any possible injuries.



### WARNING



• PUSH BUTTONS AND DIAGONAL BRACES MUST ALWAYS BE IN THE LOCKED POSITION DURING USE. • SURFACE MAY BE HOT IF LEFT IN SUN. • DO NOT STAND ON TABLE OR BENCHES. • FAILURE TO COMPLY WITH THESE WARNINGS COULD RESULT IN SERIOUS PERSONAL INJURY. • THE TABLE IS ONLY TO BE SET UP AND TAKEN DOWN BY ADULTS.



### ADVERTENCIA



• LOS BOTONES A RESORTE Y LOS SOPORTES DIAGONALES DEBEN ESTAR SIEMPRE EN LA POSICIÓN DE TRABA DURANTE EL USO DE LA UNIDAD. • LA SUPERFICIE PUEDE ESTAR CALIENTE SI SE HA DEJADO EXPUESTA AL SOL. • NO SE PARE SOBRE LA MESA NI SOBRE LOS BANCOS. • EL NO RESPETAR ESTAS ADVERTENCIAS PUEDE SER CAUSA DE SERIAS LESIONES PERSONALES. • LA MESA SOLO PUEDE SER ARMADA Y DESARMADA POR ADULTOS.



### AVERTISSEMENT



• LES BOUTONS-POUSOIRS ET LES ARMATURES DIAGONALES DOIVENT TOUJOURS ÊTRE EN POSITION VERROUILLEE PENDANT L'UTILISATION. • LA SURFACE PEUT ÊTRE CHAUDE EN CAS D'EXPOSITION AU SOLEIL. • NE PAS SE METTRE DEBOUT SUR LA TABLE OU SUR LES BANCOS LE NON RESPECT DE CES MISES EN GARDES POURRAIT ENTRAINER DES BLESSURES GRAVES. • LA TABLE NE DOIT ÊTRE MONTÉE ET DÉMONTÉE QUE PAR DES ADULTES.



WATCH FOR PINCH POINTS  
EVITEZ LES RISQUES DE PINCEMENT  
CUIDESE DE LOS PUNTOS DE PUNZANTES

Part #F020012 D

## PICNIC TABLE 2-YEAR LIMITED FACTORY WARRANTY

LIFETIME PRODUCTS, INC. RESERVES THE RIGHT TO MAKE  
SUBSTITUTIONS TO WARRANTY CLAIMS IF PARTS ARE UNAVAILABLE  
OR OBSOLETE.

1. Lifetime Picnic Tables are warranted to the original purchaser to be free from defects in material or workmanship for a period of two years from the date of original retail purchase. The word "defects" is defined as imperfections that impair the use of the product. Defects resulting from misuse, abuse or negligence will void this warranty. This warranty does not cover defects due to alteration or accident. This warranty does not cover damage caused by vandalism, rusting, "acts of nature" or any other event beyond the control of the manufacturer.
2. This warranty is nontransferable and is expressly limited to the repair or replacement of defective product. If the product is defective within the terms of this warranty, Lifetime Products, Inc. will repair or replace defective parts at no cost to the purchaser. Shipping charges to and from the factory are not covered and are the responsibility of the purchaser.
3. This warranty does not cover scratching, scuffing or other cosmetic damage that may result from normal use of the product. In addition, defects resulting from intentional damage, negligence or unreasonable use will void this warranty.
4. Liability for incidental or consequential damages is excluded to the extent permitted by law. While every attempt is made to embody the highest degree of safety in all products, freedom from injury cannot be guaranteed. The user assumes all risk of injury resulting from the use of this product. All merchandise is sold on this condition, and no representative of the company may waive or change this policy.
5. This warranty is in lieu of all other warranties expressed or implied, including warranties of merchantability or fitness for use. Neither Lifetime Products, Inc. nor any representative assumes any other liability in connection with this product.

ALL WARRANTY CLAIMS MUST BE ACCOMPANIED BY A SALES  
RECEIPT.

REPORT PRODUCT DEFECTS IN WRITING TO:

Lifetime Products, Inc., PO Box 160010 Clearfield, UT 84016-0010 or call

## PICNIC TABLE CARE INSTRUCTIONS

Congratulations on your Lifetime purchase. By following the instructions below, your new Lifetime table should provide you with years of service and enjoyment.

### Cleaning and Care

The polyethylene tabletop and benches are stain- and solvent-resistant. To clean, use a mild soap and a soft-bristled brush. Abrasive cleaning materials may scratch the plastic and are not recommended. Repair scratches or rust spots on the metal frame by sanding the affected area lightly; using a rust-preventative spray primer; and finally, spraying with a high-gloss spray enamel paint. Avoid placing a direct heat source on or near the table surface unless using a heat barrier.

For warranty details or to register your product, visit [www.lifetime.com](http://www.lifetime.com) or call +801-776-1532