

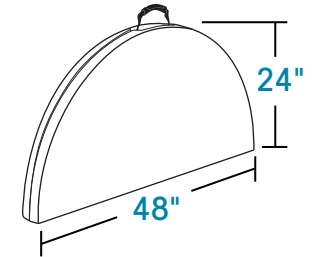

www.lifetime.com

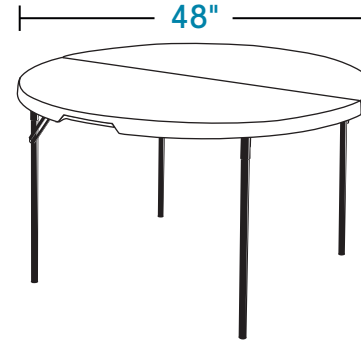

DIMENSIONS



FEATURES

- › Model Number 80064
- › Revolutionary Fold-in-Half Frame Locks Automatically
- › Double-Wall, High-Density 48" Polyethylene Tabletop
- › Stain Resistant and Easy to Clean
- › UV-Protected Tabletop will not Crack, Chip or Peel
- › Rust-Resistant Powder Coat Finish
- › Patented, Lightweight Design
- › Convenient Carry Handle
- › Indoor/Outdoor Use

48-INCH ROUND FOLD-IN-HALF TABLE

Available in white. 11 tables per pallet (for best price)

TO REQUEST A QUOTE OR PLACE AN ORDER, EMAIL DIRECTSALES@LIFETIME.COM OR CALL 1 (800) 242-3865 X1521