

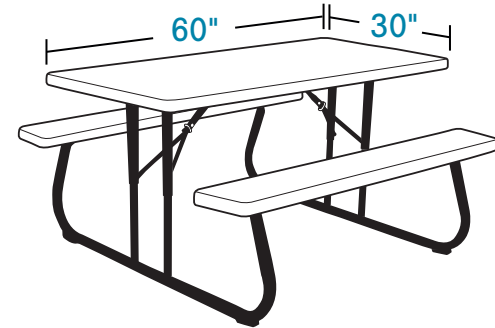

www.lifetime.com



DIMENSIONS



FEATURES

- › Model Number 2155
- › Seats Six Comfortably
- › Superior Strength and Durability
- › Folds Flat for Storage
- › Stain Resistant and Easy to Clean
- › Umbrella Hole Ready
- › Will Not Crack, Chip or Peel
- › 60" x 30" Polyethylene Tabletop
- › Some Assembly Required
- › 2-Year Warranty

5-FOOT PICNIC TABLE

Available in white and almond. 14 tables per pallet (for best price)

TO REQUEST A QUOTE OR PLACE AN ORDER, EMAIL MBMOWER@LIFETIME.COM OR CALL 1 (800) 242-3865 X1521