



www.lifetime.com



Exceeds ANSI/BIFMA Standards

## DIMENSIONS

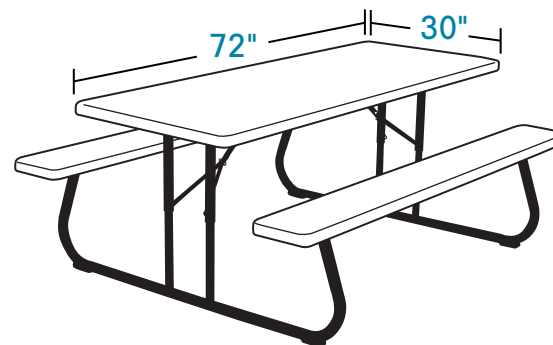

## FEATURES

- › Model Number 2119
- › Seats Eight Comfortably
- › Superior Strength and Durability
- › Folds Flat for Storage
- › Stain Resistant and Easy to Clean
- › Umbrella Hole Ready
- › Will Not Crack, Chip or Peel
- › 72" x 30" Polyethylene Tabletop
- › Some Assembly Required

## 6-FOOT PICNIC TABLE

Available in putty and hunter green. 10 tables per pallet (for best price) › 2-Year Warranty

TO REQUEST A QUOTE OR PLACE AN ORDER, EMAIL [MBMOWER@LIFETIME.COM](mailto:MBMOWER@LIFETIME.COM) OR CALL 1 (800) 242-3865 X1521